

Mark 978 Series

Sanitary Control Valves – OR Version

The Mark 978 O-Ring Series is designed to meet the rigid specifications for sanitary process control valves for customers who prefer an O-ring style stem seal. This valve series is suitable for a wide variety of applications in the bio-pharmaceutical, pharmaceutical, cosmetic, dairy and food and beverage industries.

Conforming to ASME BPE 2014 guidelines, the MK978 is ideally suited for a wide range of flowing media in both the utility and process areas of sanitary and aseptic systems.

High rangeability, characterized trim, high capacities, superior temperature and pressure ratings along with a selection of sealing methods make the MK978 the sanitary control valve for liquid, gas and steam services.

Whether the need is to control pressure, temperature, flow, pH, or another variable, the MK978 is the right valve for your process.

FEATURES

- FDA & USP Class VI compliance standard on all process seal and seat materials (except Buna-N)
- Self draining – Angle Body: when mounted in vertical (all sizes) or horizontal orientations
- No guiding in the wetted area – prevents particulate generation
- Mechanically polished internal components – 20Ra (0,5 µm) finish, electropolish – standard , 8 Ra (0,2µm) optional
- Wetted parts made of 100% 316L Stainless Steel barstock
- Maintenance-friendly – easy to perform sanitary maintenance with simple disassembly and reassembly
- Steel, baked corrosion resistant coated multi-spring actuators to meet a wide range of differential pressure requirements while providing excellent corrosion resistance during washdown



AVAILABLE FINISHES

Body

- Standard: 20 Ra mechanical finish on internal wetted surfaces (0,5 µm); machine finish on exterior (63 RMS), and electropolished inside and out
- Optional: 20 Ra mechanical finish on external surfaces (0,5 µm); 8 Ra finish on internal or external surfaces (0,2 µm)

Stem

- Standard: 20 Ra mechanical finish and electropolish (0,5 µm)
- Optional: 8 Ra mechanical finish (0,2 µm)

APPLICATIONS

A wide variety of applications exist for the MK978 in the pharmaceutical, biotech, health care, and food & beverage and other industries including:

Processes

- Fermenter
- Bioreactor
- Lyophilization
- Chromatography
- SIP/CIP Systems

Media

- Bio-process
- Caustic
- Acids
- Buffer
- Clean Steam
- WFI

SPECIFICATIONS – O-RING STEM SEAL

Sizes: 1/2" (DN15) through 2" (DN50)

Body/Bonnet Connection: bolted flange

Body/Bonnet Seal

- FDA/USP Class VI EPDM for EPDM O-Ring
- FDA/USP Class VI Viton for Viton O-Ring
- FDA/USP Class VI Jorlon for Silicon, Kalrez, Fluoraz
- Jorlon for Buna-N

Body Material: ASTM A479 316L SST Barstock

Stem Material: ASTM A479 316L SST Barstock

Bonnet Material: ASTM A479 316L SST Barstock

Stem Seal

- FDA/USP Class VI EPDM – to 275°F (+135°C)
- FDA/USP Class VI Silicon – to +450°F (+232°C)
- FDA/USP Class VI Viton® – to +400°F (+204°C)
- FDA Buna-N – to +225°F (+107°C)
- FDA/USP Class VI Kalrez® – to +450°F (+232°C)
- FDA/USP Class VI Fluoraz® – to +450°F (+232°C)

Stem Bushing: FDA PEEK (no process contact)

Actuators

Pneumatic

- 1/2" – 1" (DN15 – DN25); 35M & 55M: Steel, baked corrosion resistant coating
- 1-1/2" – 2" (DN40 – DN50); 55M & 85M: Steel, baked corrosion resistant coating

Soft Seat Option (Cv ≥ 3.5 only)

- PTFE FDA/USP Class VI to 252°F (122°C) continuous or 275°F (135°C) in intermittent (less than 15 min over 1 hour)
- PEEK FDA/USP Class VI to 350°F (177°C)

Electric

- 1/2" – 2" (DN15 – DN50)
MV1010 Cv 0.2 – 5.0 (Kv 0,17 – 4,3)
MV1020 All other Cv's

Shutoff

- Standard: ANSI Class III with metal seat
- Optional: ANSI Class VI with soft seat (Cv ≥ 3.5 only)

Ranges: 3-15, 6-30, 3-9*, or 9-15* psi (0,2-1,0; 0,4-2,0; 0,2-0,6; or 0,6-1,0 bar) (* positioner required)

Maximum Pressure @ 100°F (38°C): 450 (31 bar)

High pressure versions available, contact factory for details

Flow Characteristics: Linear, equal percentage, or quick opening (consult factory for quick opening Cv's)

Pressure/Temperature Rating

- O-Ring: 450 psi up to +450°F (31 bar up to +232°C), temperature dependent upon stem seal o-ring material

Cv (Kv) Ratings

Size	Cv (Kv) Ratings	
	Linear	Equal Percentage
1/2"	0.2 \ 0.5 \ 1.0 (0,17 / 0,43 \ 0,86)	
3/4"	1.0 \ 2.0 \ 3.5 \ 5.0 (0,86 \ 1,72 \ 3,01 \ 4,30)	
1"	3.5 \ 5.0 (3,01 \ 4,30)	
	7.5 \ 15.0 (6,45 \ 12,90)	
1-1/2"	5.0 \ 10 \ 15 \ 20 \ 30 (4,3 \ 8,6 \ 12,9 \ 17,2 \ 25,0)	
2"	10 \ 15 \ 20 \ 30 (8,6 \ 12,9 \ 17,20 \ 25,80)	
	40 \ 60 (34,40 \ 51,60)	40 (34,40)

MAXIMUM Δ Ratings, PSI (BAR)

Valve Size	Valve Cv	Actuator Size	ATO 3-15	ATO 6-30 or with positioner @ 40 psi	ATC 3-15 or with positioner @ 20 psi	ATC 6-30 @ 40 psi
1/2"	0.2 / 0.5 / 1.0	35M / 55M	450 (31)	450 (31)	450 (31)	450 (31)
3/4"	1.0 / 2.0 / 3.5 / 5.0	35M	396	450 (31)	396 (27,3)	450 (31)
3/4"	1.0 / 2.0 / 3.5 / 5.0	55M	450 (31)	450 (31)	450 (31)	450 (31)
1"	3.5 / 5.0	35M	150 (10,3)	216 (14,9)	150 (10,3)	450 (31)
1"	3.5 / 5.0	55M	316 (21,8)	416 (28,7)	316 (21,8)	450 (31)
1"	7.5 / 15	35M	75 (5,2)	120 (8,3)	75 (5,2)	300 (20,7)
1"	7.5 / 15	55M	188 (13,0)	256 (17,7)	188 (13,0)	450 (31)
1-1/2"	5 / 10 / 15	55M	86 (5,9)	126 (8,7)	86 (5,9)	288 (19,9)
1-1/2"	5 / 10 / 15	85M	220 (15,2)	288 (19,9)	220 (15,2)	450 (31)
1-1/2"	20 / 30	55M	63 (4,3)	97 (6,7)	63 (4,3)	232 (16,0)
1-1/2"	20 / 30	85M	176 (12,1)	232 (16,0)	176 (12,1)	450 (31)
2"	10/15/20/30/40/60	55M	15 (1,0)	34 (2,3)	15 (1,0)	111 (7,7)
2"	10/15/20/30/40/60	85M	79 (5,4)	111 (7,7)	79 (5,4)	238 (16,4)

Note: for pressure drop capabilities of electric actuators, please consult factory

Note: 1/2" – 2" with positioner ATO actuator is bench set @ 6-30 psi/ ATC actuator is bench set @ 3-15 psi

O-RING STEM SEAL (ANGLE STYLE (1/2"-1"))

NEW Bi-direction flow capability. Valve can be installed with inlet on side or bottom. Self draining when valve is installed with inlet on side and valve in upright position as shown.

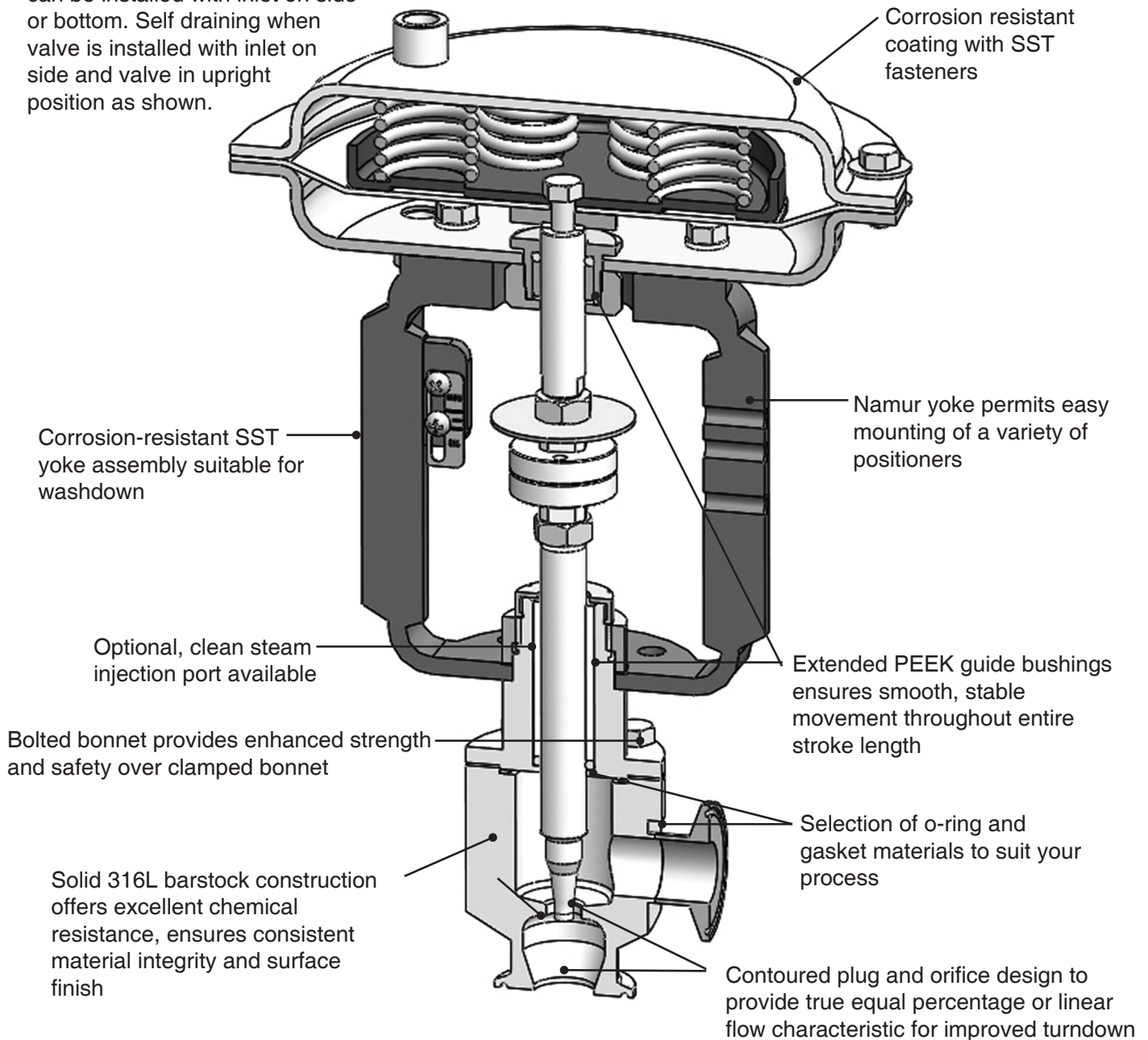

SPECIFICATION

Stainless steel sanitary control valve shall be made from ASTM A479 316L barstock material, which includes body and all wetted metal parts. Control valve with the stem sealed by FDA approved and USP Class VI certified Jorlon diaphragm with lifetime warranty. The valve stem shall be supported by a one piece, SS NAMUR Yoke with two extended PEEK™ Guide bushings to provide structural rigidity and true guiding in any installation orientation. Guiding of valve stem/plug shall be outside of the wetted process areas of valve above diaphragm. Control valve shall have secondary stem seal, and extended guide bushing to provide additional support for multiple installation orientations. Valve shall be self draining in at least one orientation.

O-RING STEM SEAL (1-1/2" – 2")

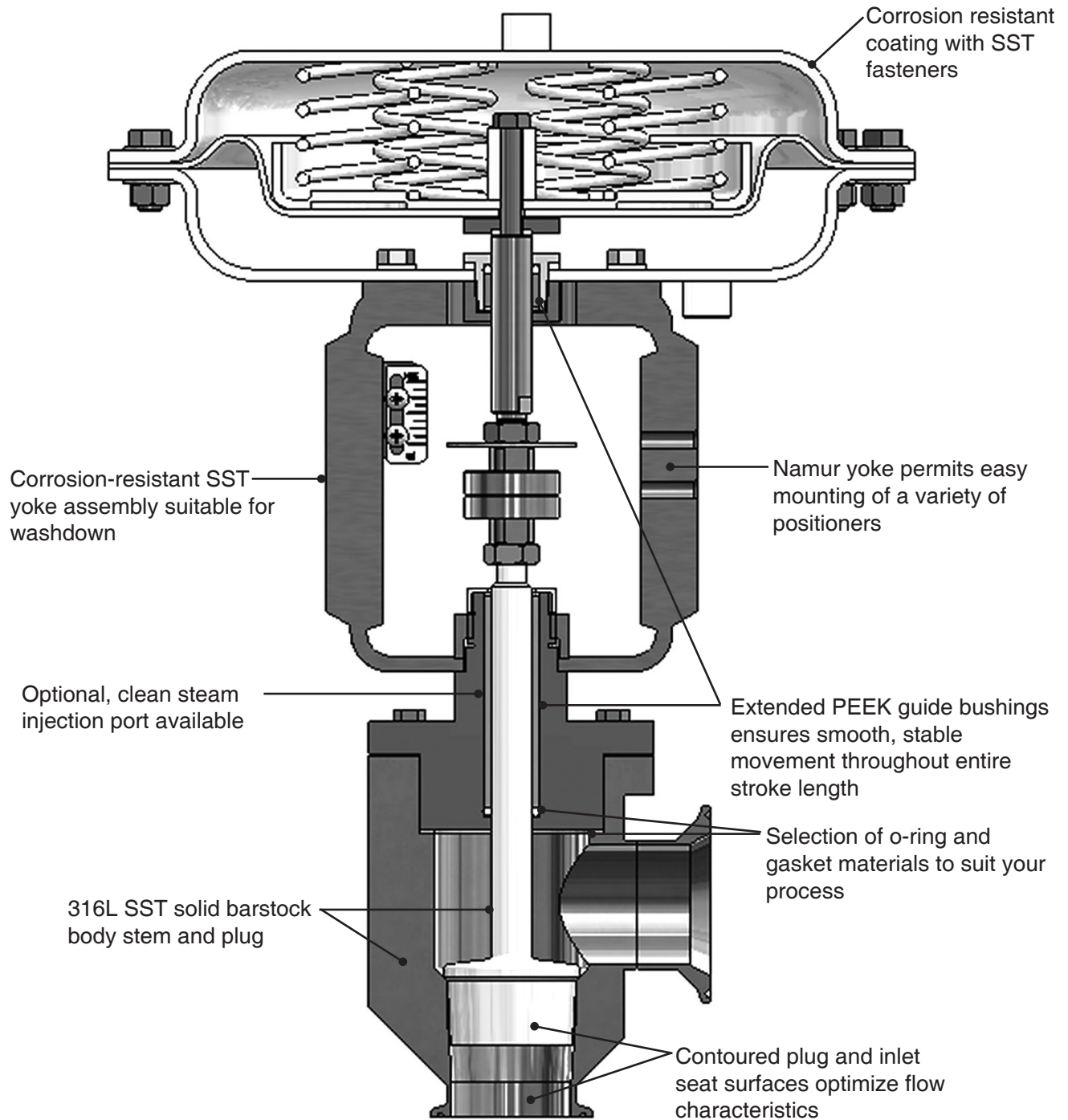

SPECIFICATION

Stainless Steel sanitary control valve shall be made from ASTM A479 barstock material, which includes body and all wetted parts. Valve stem sealed by FDA/USP Class VI approved material o-ring. Guiding of valve stem/plug shall be outside of the wetted process areas of the valve above the o-ring. The control valve shall be free of threads within the wetted process area. Valve shall have one piece SS Namur Yoke enabling Namur positioner bracketing and providing stem stabilization for Horizontal mounting. Valve is self draining in any orientation.

DIMENSIONS

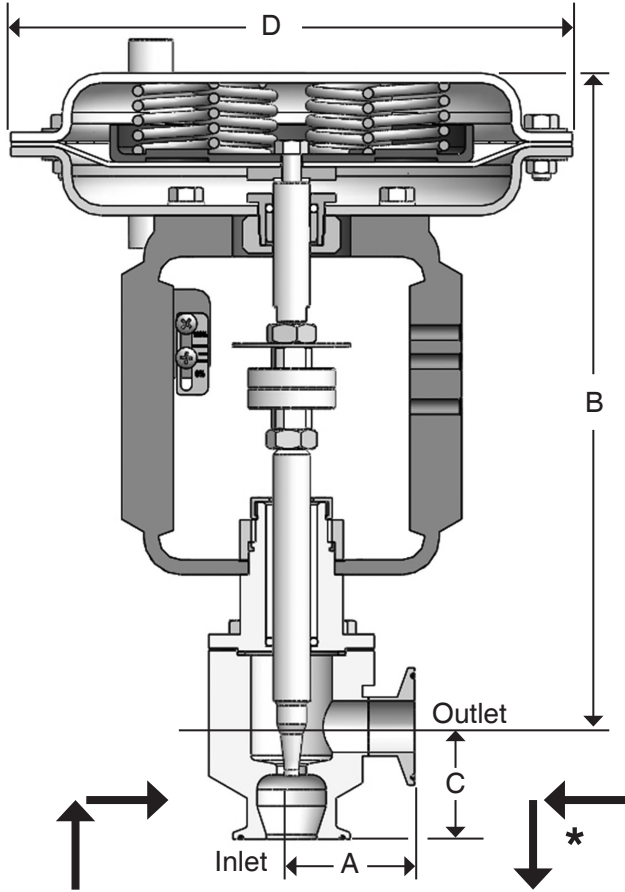

INCHES

Valve Size	Dimensions				Weight Lbs
	A	B	C	D	
1/2"	2.08	11.94	1.91	9.50 (35M)	27 (35M)
				12.50 (55M)	42 (55M)
3/4"	2.08	11.94	1.91	9.50 (35M)	27 (35M)
				12.50 (55M)	42 (55M)
1"	2.08	11.94	1.91	9.50 (35M)	27 (35M)
				12.50 (55M)	42 (55M)

METRIC

Valve Size	Dimensions				Weight Kgs
	A	B	C	D	
DN15	53	303	49	241 (35M)	12 (35M)
				318 (55M)	19 (55M)
DN20	53	303	49	241 (35M)	12 (35M)
				318 (55M)	19 (55M)
DN25	53	303	49	241 (35M)	12 (35M)
				318 (55M)	19 (55M)

Based on US tri-clamp ends. Consult factory for DIN and ISO tri-clamp end dimensions

Installation and Drainability:

- Valve is bi-directional, flow can enter either connection
- When valve is open, there is no hold up volume
- * For gravity drainage from inlet to outlet, install as shown above.

DIMENSIONS

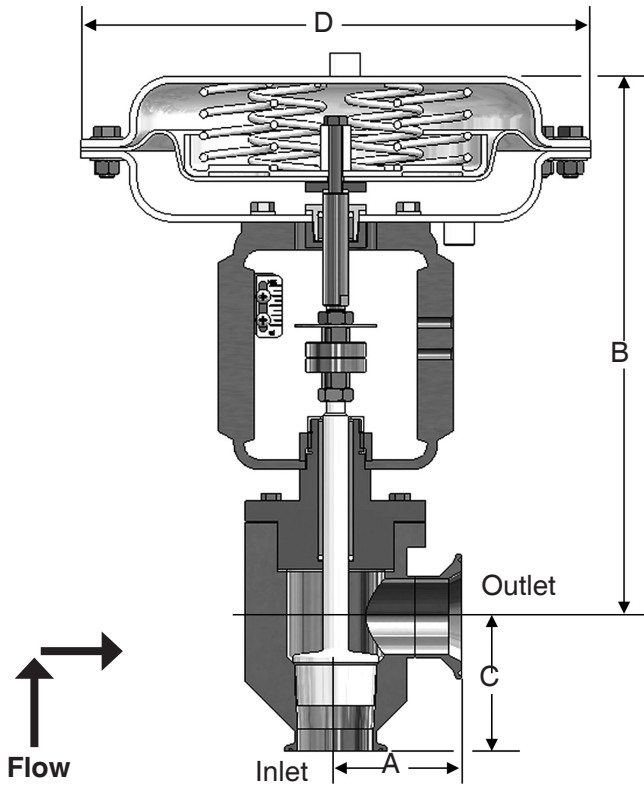

INCHES

Valve Size	Dimensions				Weight Lbs
	A	B	C	D	
1-1/2"	3.08	15.00	3.30	12.50 (55M)	47 (35M)
				15.00 (85M)	57 (55M)
2"	3.08	15.00	3.30	12.50 (55M)	47 (35M)
				15.00 (85M)	57 (55M)

METRIC

Valve Size	Dimensions				Weight Kgs
	A	B	C	D	
DN40	78	381	84	318 (55M)	21 (35M)
				381 (85M)	26 (55M)
DN50	78	381	84	318 (55M)	21 (35M)
				381 (85M)	26 (55M)

Based on US tri-clamp ends. Consult factory for DIN and ISO tri-clamp end dimensions

Installation and Drainability:

- Valve has no hold-up when installed as shown above, but must be drained below inlet.
- Valve will gravity drain from inlet to outlet when installed with inlet horizontal (outlet facing down)

ORDERING SCHEMATIC - MK978E SERIES (1/2" - 1")

Model No	Size	Stem Seal / Seat	1	2	3	4	5	6	7	8	9	10	11	12	13	14	15

	Model
978E	Standard
978EMV	Motor Valve
978ESP	Side Mounted Positioner
978ETP	Top Mounted Positioner

	Stem Seal / Seat
OR	O-Ring / Hard Seat
ORP	O-Ring / PEEK FDA/USP Class VI (Cv ≥ 3.5 only)
ORT	O-Ring / Teflon FDA/USP Class VI (Cv ≥ 3.5 only)

	Size
050	1/2"
075	3/4"
100	1"

MARK 978 SANITARY GLOBE-STYLE CONTROL VALVES - O-RING STEM SEAL

1,2,3,4,5,6	1/2" Tri-C Body, Cv, Char. Finish
AALN1A	1/2" LIN Cv 0.2 20Ra int./63 RMS ext.
A1LN1A	1/2" LIN Cv 0.2 20Ra int./20Ra ext.
A2LN1Ø	1/2" LIN Cv 0.2 8Ra int./20Ra ext.
A3LN1Ø	1/2" LIN Cv 0.2 8Ra int./8Ra ext.
A4LN1Ø	1/2" LIN Cv 0.2 8Ra int./63RMS ext.
AAEPA1	1/2" EQP Cv 0.2 20Ra int./63 RMS ext.
A1EPA1	1/2" EQP Cv 0.2 20Ra int./20Ra ext.
A2EP11	1/2" EQP Cv 0.2 8Ra int./20Ra ext.
A3EP11	1/2" EQP Cv 0.2 8Ra int./8Ra ext.
A4EP11	1/2" EQP Cv 0.2 8Ra int./63 RMS ext.
AALN2A	1/2" LIN Cv 0.5 20Ra int./63RMS ext.
A1LN2A	1/2" LIN Cv 0.5 20Ra int./20Ra ext.
A2LN21	1/2" LIN Cv 0.5 8Ra int./20Ra ext.
A3LN21	1/2" LIN Cv 0.5 8Ra int./8Ra ext.
A4LN21	1/2" LIN Cv 0.5 8Ra int./63 RMS ext.
AAEPA2	1/2" EQP Cv 0.5 20Ra int./63 RMS ext.
A1EPA2	1/2" EQP Cv 0.5 20Ra int./20Ra ext.
A2EP12	1/2" EQP Cv 0.5 8Ra int./20Ra ext.
A3EP12	1/2" EQP Cv 0.5 8Ra int./8Ra ext.
A4EP12	1/2" EQP Cv 0.5 8Ra int./63 RMS ext.
AALN3A	1/2" LIN Cv 1.0 20Ra int./63 RMS ext.
A1LN3A	1/2" LIN Cv 1.0 20Ra int./20Ra ext.
A2LN31	1/2" LIN Cv 1.0 8Ra int./20Ra ext.
A3LN31	1/2" LIN Cv 1.0 8Ra int./8Ra ext.
A4LN31	1/2" LIN Cv 1.0 8Ra int./63 RMS ext.
AAEPA3	1/2" EQP Cv 1.0 20Ra int./63 RMS ext.
A1EPA3	1/2" EQP Cv 1.0 20Ra int./20Ra ext.
A2EP13	1/2" EQP Cv 1.0 8Ra int./20Ra ext.
A3EP13	1/2" EQP Cv 1.0 8Ra int./8Ra ext.
A4EP13	1/2" EQP Cv 1.0 8Ra int./63 RMS ext.

1,2,3,4,5,6	3/4" Tri-C Body, Cv, Char. Finish
BALN1A	3/4" LIN Cv 1.0 20Ra int./63 RMS ext.
B1LN1A	3/4" LIN Cv 1.0 20Ra int./20Ra ext.
B2LN1Ø	3/4" LIN Cv 1.0 8Ra int./20Ra ext.
B3LN1Ø	3/4" LIN Cv 1.0 8Ra int./8Ra ext.
B4LN1Ø	3/4" LIN Cv 1.0 8Ra int./63 RMS ext.
BAEPA1	3/4" EQP Cv 1.0 20Ra int./63 RMS ext.
B1EPA1	3/4" EQP Cv 1.0 20Ra int./20Ra ext.
B2EP11	3/4" EQP Cv 1.0 8Ra int./20Ra ext.
B3EP11	3/4" EQP Cv 1.0 8Ra int./8Ra ext.
B4EP11	3/4" EQP Cv 1.0 8Ra int./63 RMS ext.
BALN2A	3/4" LIN Cv 2.0 20Ra int./63 RMS ext.
B1LN2A	3/4" LIN Cv 2.0 20Ra int./20Ra ext.
B2LN21	3/4" LIN Cv 2.0 8Ra int./20Ra ext.
B3LN21	3/4" LIN Cv 2.0 8Ra int./8Ra ext.
B4LN21	3/4" LIN Cv 2.0 8Ra int./63 RMS ext.

1,2,3,4,5,6	3/4" Tri-C Body, Cv, Char. Finish
BAEPA2	3/4" EQP Cv 2.0 20Ra int./63 RMS ext.
B1EPA2	3/4" EQP Cv 2.0 20Ra int./20Ra ext.
B2EP12	3/4" EQP Cv 2.0 8Ra int./20Ra ext.
B3EP12	3/4" EQP Cv 2.0 8Ra int./8Ra ext.
B4EP12	3/4" EQP Cv 2.0 8Ra int./63 RMS ext.
CALN3A	3/4" LIN Cv 3.5 20Ra int./63 RMS ext.
C1LN3A	3/4" LIN Cv 3.5 20Ra int./20Ra ext.
C2LN31	3/4" LIN Cv 3.5 8Ra int./20Ra ext.
C3LN31	3/4" LIN Cv 3.5 8Ra int./8Ra ext.
C4LN31	3/4" LIN Cv 3.5 8Ra int./63 RMS ext.
CAEPA3	3/4" EQP Cv 3.5 20Ra int./63 RMS ext.
C1EPA3	3/4" EQP Cv 3.5 20Ra int./20Ra ext.
C2EP13	3/4" EQP Cv 3.5 8Ra int./20Ra ext.
C3EP13	3/4" EQP Cv 3.5 8Ra int./8Ra ext.
C4EP13	3/4" EQP Cv 3.5 8Ra int./63 RMS ext.
CALN4A	3/4" LIN Cv 5.0 20Ra int./63 RMS ext.
C1LN4A	3/4" LIN Cv 5.0 20Ra int./20Ra ext.
C2LN41	3/4" LIN Cv 5.0 8Ra int./20Ra ext.
C3LN41	3/4" LIN Cv 5.0 8Ra int./8Ra ext.
C4LN41	3/4" LIN Cv 5.0 8Ra int./63 RMS ext.
CAEPA4	3/4" EQP Cv 5.0 20Ra int./63 RMS ext.
C1EPA4	3/4" EQP Cv 5.0 20Ra int./20Ra ext.
C2EP14	3/4" EQP Cv 5.0 8Ra int./20Ra ext.
C3EP14	3/4" EQP Cv 5.0 8Ra int./8Ra ext.
C4EP14	3/4" EQP Cv 5.0 8Ra int./63 RMS ext.

1,2,3,4,5,6	1" Tri-C Body, Cv, Char. Finish
DALN1A	1" LIN Cv 3.5 20Ra int./63 RMS ext.
D1LN1A	1" LIN Cv 3.5 20Ra int./20Ra ext.
D2LN1Ø	1" LIN Cv 3.5 8Ra int./20Ra ext.
D3LN1Ø	1" LIN Cv 3.5 8Ra int./8Ra ext.
D4LN1Ø	1" LIN Cv 3.5 8Ra int./63 RMS ext.
DAEPA1	1" EQP Cv 3.5 20Ra int./63 RMS ext.
D1EPA1	1" EQP Cv 3.5 20Ra int./20Ra ext.
D2EP11	1" EQP Cv 3.5 8Ra int./20Ra ext.
D3EP11	1" EQP Cv 3.5 8Ra int./8Ra ext.
D4EP11	1" EQP Cv 3.5 8Ra int./63 RMS ext.
DALN2A	1" LIN Cv 5.0 20Ra int./63 RMS ext.
D1LN2A	1" LIN Cv 5.0 20Ra int./20Ra ext.
D2LN21	1" LIN Cv 5.0 8Ra int./20Ra ext.
D3LN21	1" LIN Cv 5.0 8Ra int./8Ra ext.
D4LN21	1" LIN Cv 5.0 8Ra int./63 RMS ext.
DAEPA2	1" EQP Cv 5.0 20Ra int./63 RMS ext.
D1EPA2	1" EQP Cv 5.0 20Ra int./20Ra ext.
D2EP12	1" EQP Cv 5.0 8Ra int./20Ra ext.
D3EP12	1" EQP Cv 5.0 8Ra int./8Ra ext.
D4EP12	1" EQP Cv 5.0 8Ra int./63 RMS ext.

ORDERING SCHEMATIC CONTINUED

1,2,3,4,5,6	1" Tri-C Body, Cv, Char. Finish
EALN3A	1" LIN Cv 7.5 20Ra int./63 RMS ext.
E1LN3A	1" LIN Cv 7.5 20Ra int./20Ra ext.
E2LN31	1" LIN Cv 7.5 8Ra int./20Ra ext.
E3LN31	1" LIN Cv 7.5 8Ra int./8Ra ext.
E4LN31	1" LIN Cv 7.5 8Ra int./63 RMS ext.
EAEP3A	1" EQP Cv 7.5 20Ra int./63 RMS ext.
E1EP3A	1" EQP Cv 7.5 20Ra int./20Ra ext.
E2EP13	1" EQP Cv 7.5 8Ra int./20Ra ext.
E3EP13	1" EQP Cv 7.5 8Ra int./8Ra ext.
E4EP13	1" EQP Cv 7.5 8Ra int./63 RMS ext.
EALN4A	1" LIN Cv 15 20Ra int./63 RMS ext.
E1LN4A	1" LIN Cv 15 20Ra int./20Ra ext.
E2LN41	1" LIN Cv 15 8Ra int./20Ra ext.
E3LN41	1" LIN Cv 15 8Ra int./8Ra ext.
E4LN41	1" LIN Cv 15 8Ra int./63 RMS ext.
EAEP4A	1" EQP Cv 15 20Ra int./63 RMS ext.
E1EP4A	1" EQP Cv 15 20Ra int./20Ra ext.
E2EP14	1" EQP Cv 15 8Ra int./20Ra ext.
E3EP14	14" EQP Cv 15 8Ra int./8Ra ext.
E4EP14	1" EQP Cv 15 8Ra int./63 RMS ext.

7 & 8	Stem Seal
	O-Ring Seal
BN	Buna-N / FDA
EP	EPDM / FDA & USP Class VI
FZ	Fluoraz / FDA & USP Class VI
KZ	Kalrez / FDA & USP Class VI
SI	Silicone / FDA & USP Class VI
VI	Viton / FDA & USP Class VI

9 & 10	Actuator / Range
	978 / 978TP
3D	35M 3-15 DIR
3R	35M 3-15 REV
4D	35M 6-30 DIR
4R	35M 6-30 REV
5D	55M 3-15 DIR
5R	55M 3-15 REV
6D	55M 6-30 DIR
6R	55M 6-30 REV
	978SP
3D	35M ALL DIR
3R	35M ALL REV
5D	55M ALL DIR
5R	55M ALL REV
	978MV
1D	MV1010 4-20MA DIR 0.2 - 5.0 Cv
1R	MV1010 4-20MA REV 0.2 - 5.0 Cv
2D	MV1020 4-20MA DIR All Cv
2R	MV1020 4-20MA DIR All Cv

11 & 12	Action
DD	Direct
RR	Reverse

13 & 14	Accessories
00	None
1A	I/P Trans. 4-20M / 3-15P
2A	Air Reg. with gage
3A	I/P Trans. 4-20M / 6-30P

15	SMP
0	None
A	SMP DIR / REV 3-15
B	SMP DIR / REV 3-9
C	SMP DIR / REV 9-15
D	SMP / IP DIR / REV 4-20
E	SMP / IP DIR / REV 4-12
F	SMP / IP DIR / REV 12-20
G	MK16IQ - S DIR / REV 4-20 (HART®)
H	MK16IQ - B DIR / REV 4-20 (not HART®)
J	MK16IQ - FF DIR / REV 4-20 (Foundation Fieldbus™)

ORDERING SCHEMATIC - MARK 978 SERIES (1-1/2" & 2")

Model No	Size	Stem Seal	Seat	1	2	3	4	5	6	7	8	9	10	11	12	13	14	15

	Model
978	Standard
978MV	Motor Valve
978SP	Side Mounted Positioner
978TP	Top Mounted Positioner

	Size
150	1-1/2"
200	2"

	Stem Seal
OR	O-Ring

	Seat
	Leave blank for standard Hard Seat
P	PEEK FDA/USP Class VI
T	Teflon FDA/USP Class VI

1,2,3,4,5,6	1-1/2" Tri-C Body, Cv, Char. Finish
FALN1A	1-1/2" LIN Cv 5 20Ra int./63 RMS. ext.
F1LN1A	1-1/2" LIN Cv 5 20Ra int./20Ra ext.
F2LN1Ø	1-1/2" LIN Cv 5 8Ra int. /20Ra ext.
F3LN1Ø	1-1/2" LIN Cv 5 8Ra int./8Ra ext.
F4LN1Ø	1-1/2" LIN Cv 5 8Ra int./63RMS ext.
FAEPA1	1-1/2" EQP Cv 5 20Ra int./63 RMS ext.
F1EPA1	1-1/2" EQP Cv 5 20Ra int./20Ra ext.
F2EP11	1-1/2" EQP Cv 5 8Ra int./20Ra ext.
F3EP11	1-1/2" EQP Cv 5 8Ra int./8Ra ext.
F4EP11	1-1/2" EQP Cv 5 8Ra int./63 RMS ext.
FALN2A	1-1/2" LIN Cv 10 20Ra int./63 RMS. ext.
F1LN2A	1-1/2" LIN Cv 10 20Ra int./20Ra ext.
F2LN21	1-1/2" LIN Cv 10 8Ra int. /20Ra ext.
F3LN21	1-1/2" LIN Cv 10 8Ra int./8Ra ext.
F4LN21	1-1/2" LIN Cv 10 8Ra int./63 RMS ext.
FAEPA2	1-1/2" EQP Cv 10 20Ra int./63 RMS. ext.
F1EPA2	1-1/2" EQP Cv 10 20Ra int./20Ra ext.
F2EP12	1-1/2" EQP Cv 10 8Ra int. /20Ra ext.
F3EP12	1-1/2" EQP Cv 10 8Ra int./8Ra ext.
F4EP12	1-1/2" EQP Cv 10 8Ra int./63 RMS ext.
FALN3A	1-1/2" LIN Cv 15 20Ra int./63 RMS. ext.
F1LN3A	1-1/2" LIN Cv 15 20Ra int./20Ra ext.
F2LN31	1-1/2" LIN Cv 15 8Ra int. /20Ra ext.
F3LN31	1-1/2" LIN Cv 15 8Ra int./8Ra ext.
F4LN31	1-1/2" LIN Cv 15 8Ra int./63 RMS ext.

1,2,3,4,5,6	1-1/2" Tri-C Body, Cv, Char. Finish
FAEPA3	1-1/2" EQP Cv 15 20Ra int./63 RMS. ext.
F1EPA3	1-1/2" EQP Cv 15 20Ra int./20Ra ext.
F2EP13	1-1/2" EQP Cv 15 8Ra int. /20Ra ext.
F3EP13	1-1/2" EQP Cv 15 8Ra int./8Ra ext.
F4EP13	1-1/2" EQP Cv 15 8Ra int./63 RMS ext.
GALN4A	1-1/2" LIN Cv 20 20Ra int./63 RMS. ext.
G1LN4A	1-1/2" LIN Cv 20 20Ra int./20Ra ext.
G2LN41	1-1/2" LIN Cv 20 8Ra int. /20Ra ext.
G3LN41	1-1/2" LIN Cv 20 8Ra int./8Ra ext.
G4LN41	1-1/2" LIN Cv 20 8Ra int./63 RMS ext.
GAEPA4	1-1/2" EQP Cv 20 20Ra int./63 RMS ext.
G1EPA4	1-1/2" EQP Cv 20 20Ra int./20Ra ext.
G2EP14	1-1/2" EQP Cv 20 8Ra int./20Ra ext.
G3EP14	1-1/2" EQP Cv 20 8Ra int./8Ra ext.
G4EP14	1-1/2" EQP Cv 20 8Ra int./63 RMS ext.
GALN5A	1-1/2" LIN Cv 30 20Ra int./63 RMS. ext.
G1LN5A	1-1/2" LIN Cv 30 20Ra int./20Ra ext.
G2LN51	1-1/2" LIN Cv 30 8Ra int. /20Ra ext.
G3LN51	1-1/2" LIN Cv 30 8Ra int./8Ra ext.
G4LN51	1-1/2" LIN Cv 30 8Ra int./63 RMS ext.
GAEPA5	1-1/2" EQP Cv 30 20Ra int./63 RMS. ext.
G1EPA5	1-1/2" EQP Cv 30 20Ra int./20Ra ext.
G2EP15	1-1/2" EQP Cv 30 8Ra int. /20Ra ext.
G3EP15	1-1/2" EQP Cv 30 8Ra int./8Ra ext.
G4EP15	1-1/2" EQP Cv 30 8Ra int./63 RMS ext.

1,2,3,4,5,6	2" Tri-C Body, Cv, Char. Finish
HALN1A	2" LIN Cv 10 20Ra int./63 RMS. ext.
H1LN1A	2" LIN Cv 10 20Ra int./20Ra ext.
H2LN1Ø	2" LIN Cv 10 8Ra int. /20Ra ext.
H3LN1Ø	2" LIN Cv 10 8Ra int./8Ra ext.
H4LN1Ø	2" LIN Cv 10 8Ra int./63 RMS ext.
HAEPA1	2" EQP Cv 10 20Ra int./63 RMS. ext.
H1EPA1	2" EQP Cv 10 20Ra int./20Ra ext.
H2EP11	2" EQP Cv 10 8Ra int. /20Ra ext.
H3EP11	2" EQP Cv 10 8Ra int./8Ra ext.
H4EP11	2" EQP Cv 10 8Ra int./63 RMS ext.
HALN2A	2" LIN Cv 15 20Ra int./63 RMS. ext.
H1LN2A	2" LIN Cv 15 20Ra int./20Ra ext.
H2LN21	2" LIN Cv 15 8Ra int. /20Ra ext.
H3LN21	2" LIN Cv 15 8Ra int./8Ra ext.
H4LN21	2" LIN Cv 15 8Ra int./63 RMS ext.

Continued on next page

ORDERING SCHEMATIC CONTINUED (1-1/2" & 2")

1,2,3,4,5,6	2" Tri-C Body, Cv, Char. Finish
HAEPA2	2" EQP Cv 15 20Ra int./63 RMS. ext.
H1EPA2	2" EQP Cv 15 20Ra int./20Ra ext.
H2EP12	2" EQP Cv 15 8Ra int./20Ra ext.
H3EP12	2" EQP Cv 15 8Ra int./8Ra ext.
H4EP12	2" EQP Cv 15 8Ra int./63 RMS ext.
HALN3A	2" LIN Cv 20 20Ra int./63 RMS. ext.
H1LN3A	2" LIN Cv 20 20Ra int./20Ra ext.
H2LN31	2" LIN Cv 20 8Ra int./20Ra ext.
H3LN31	2" LIN Cv 20 8Ra int./8Ra ext.
H4LN31	2" LIN Cv 20 8Ra int./63 RMS ext.
HAEPA3	2" EQP Cv 20 20Ra int./63 RMS ext.
H1EPA3	2" EQP Cv 20 20Ra int./20Ra ext.
H2EP13	2" EQP Cv 20 8Ra int./20Ra ext.
H3EP13	2" EQP Cv 20 8Ra int./8Ra ext.
H4EP13	2" EQP Cv 20 8Ra int./63 RMS ext.
HALN4A	2" LIN Cv 30 20Ra int./63 RMS. ext.
H1LN4A	2" LIN Cv 30 20Ra int./20Ra ext.
H2LN41	2" LIN Cv 30 8Ra int./20Ra ext.
H3LN41	2" LIN Cv 30 8Ra int./8Ra ext.
H4LN41	2" LIN Cv 30 8Ra int./63 RMS ext.
HAEPA4	2" EQP Cv 30 20Ra int./63 RMS. ext.
H1EPA4	2" EQP Cv 30 20Ra int./20Ra ext.
H2EP14	2" EQP Cv 30 8Ra int./20Ra ext.
H3EP14	2" EQP Cv 30 8Ra int./8Ra ext.
H4EP14	2" EQP Cv 30 8Ra int./63 RMS ext.
IALN5A	2" LIN Cv 40 20Ra int./63 RMS. ext.
I1LN5A	2" LIN Cv 40 20Ra int./20Ra ext.
I2LN51	2" LIN Cv 40 8Ra int./20Ra ext.
I3LN51	2" LIN Cv 40 8Ra int./8Ra ext.
I4LN51	2" LIN Cv 40 8Ra int./63 RMS ext.
IAEPA5	2" EQP Cv 40 20Ra int./63 RMS. ext.
I1EPA5	2" EQP Cv 40 20Ra int./20Ra ext.
I2EP15	2" EQP Cv 40 8Ra int./20Ra ext.
I3EP15	2" EQP Cv 40 8Ra int./8Ra ext.
I4EP15	2" EQP Cv 40 8Ra int./63 RMS ext.
IALN6A	2" LIN Cv 60 20Ra int./63 RMS. ext.
I1LN6A	2" LIN Cv 60 20Ra int./20Ra ext.
I2LN61	2" LIN Cv 60 8Ra int./20Ra ext.
I3LN61	2" LIN Cv 60 8Ra int./8Ra ext.
I4LN61	2" LIN Cv 60 8Ra int./63 RMS ext.

7 & 8	Stem Seal
	O-Ring Seal
BN	Buna-N / FDA
EP	EPDM / FDA & USP Class VI
FZ	Fluoraz / FDA & USP Class VI
KZ	Kalrez / FDA & USP Class VI
SI	Silicone / FDA & USP Class VI
VI	Viton / FDA & USP Class VI

9 & 10	Actuator / Range
	978 / 978TP
5D	55M 3-15 DIR
5R	55M 3-15 REV
6D	55M 6-30 DIR
6R	55M 6-30 REV
8D	85M 3-15 DIR
8R	85M 3-15 REV
9D	85M 6-30 DIR
9R	85M 6-30 REV
	978SP
5D	55M ALL DIR
5R	55M ALL REV
8D	85M ALL DIR
8R	85M ALL REV
	978MV
2D	MV1020 4-20MA DIR All Cv
2R	MV1020 4-20MA DIR All Cv

11 & 12	Action
DD	Direct
RR	Reverse

13 & 14	Accessories
00	None
1A	I/P Trans. 4-20M / 3-15P
2A	Air Reg. with gage
3A	I/P Trans. 4-20M / 6-30P

15	SMP
0	None
A	SMP DIR / REV 3-15
B	SMP DIR / REV 3-9
C	SMP DIR / REV 9-15
D	SMP / IP DIR / REV 4-20
E	SMP / IP DIR / REV 4-12
F	SMP / IP DIR / REV 12-20
G	MK16IQ - S DIR / REV 4-20 (HART®)
H	MK16IQ - B DIR / REV 4-20 (not HART®)
J	MK16IQ - FF DIR / REV 4-20 (Foundation Fieldbus™)